

## DAX AUTOMATIC CHROME FINISH COMMERCIAL SENSOR FAUCET SPECS

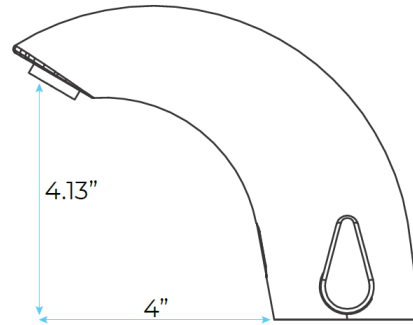

### Specs:

- ▶ Drastically reduces water consumption
- ▶ No physical contact. Helps to protect users against cross contamination
- ▶ Lead free (Except for BM versions)
- ▶ One piece construction, ideal for heavy duty areas
- ▶ Sensor settings adjustable by remote control
- ▶ Easy installation
- ▶ Internal solenoid valve
- ▶ Dia.of inlet / outlet pipe: G1/2"
- ▶ Flux:  $\geq 0.07\text{L/S}$
- ▶ Temperature:  $0.1\text{-}50^{\circ}\text{C}$

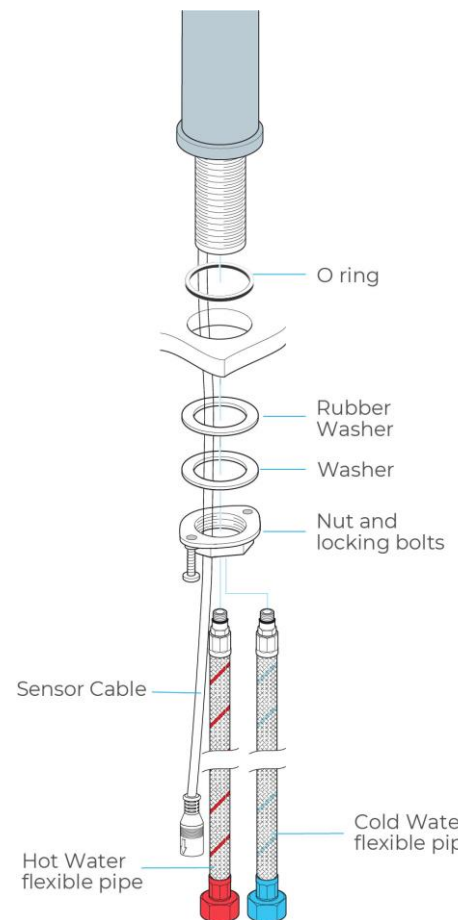

[Visit Product Page](#)